

Sonic Dismembrator

ULTRASONIC PROCESSOR

Part No. FB-120

OPERATION MANUAL



For customer service, call 1-800-766-7000.
To fax an order, use 1-800-926-1166.
To order online: www.fishersci.com

Table of Contents

<u>Section</u>	<u>Page No.</u>
1. Warranty	4
2. Warnings	5-6
3. Specifications	7-8
4. Principles of Operation	9-10
5. Description of Components / Functions of Controls	11-13
6. Preparation for Use	14
7. Operating Instructions	15-18
8. Accessories	19
9. Maintenance	20-22
10. Troubleshooting	22
11. Service / Return of Equipment	23
12. Service Safety Certification form	24

1. Warranty

Your ultrasonic processor is warranted and backed by the manufacturer for a period of two years from the date of shipment against defects in material and workmanship under normal use as described in this instruction manual. During the warranty period, the manufacturer will, at its option, as the exclusive remedy, either repair or replace without charge for material and labor, the part(s) which prove to be defective, provided the unit is returned to us properly packed with all transportation charges prepaid.

Ultrasonic probes are guaranteed against defects for a period of one year from date of shipment. A defective probe will be replaced once without charge, if failure occurs within the warranty period. Wear resulting from cavitation erosion is a normal consequence of ultrasonic processing, and is not covered by this warranty.

The manufacturer neither assumes nor authorizes any person to assume for it any other obligations or liability in connection with the sale of its products. The manufacturer hereby disclaims any warranty of either merchantability or fitness for a particular purpose. No person or company is authorized to change, modify, or amend the terms of this warranty in any manner or fashion whatsoever. Under no circumstances shall the manufacturer be liable to the purchaser or any other person for any incidental or consequential damages or loss of goodwill, production, or profit resulting from any malfunction or failure of its product.

This warranty does not apply to equipment that has been subject to unauthorized repair, misuse, abuse, negligence or accident. Equipment which, shows evidence of having been used in violation of operating instructions, or which has had the serial number altered or removed, will be ineligible for service under this warranty.

All probes are manufactured to exacting specifications and are tuned to vibrate at a specific frequency. Using an out-of-tune probe will cause damage to the equipment and may result in warranty nullification. The manufacturer assumes no responsibility for probes fabricated by another party or for consequential damages resulting from their usage.

The aforementioned provisions do not extend the original warranty period of any product that has either been repaired or replaced by the manufacturer.

2. Warnings

Please read the manual in its entirety. Necessary instruction and guidance are provided to help ensure the successful operation of this device.

Your new ultrasonic liquid processor has been designed, built and tested to assure maximum operator safety. However, no design can completely protect against improper use that may lead to bodily injury and/or property damage. For total safety and equipment protection, read the instruction manual carefully before attempting to operate this equipment. Observe the following **WARNINGS**:

- High voltage is present in the generator (power supply), converter and high frequency cable. There are no user-serviceable parts inside any of these devices. Do NOT attempt to remove the generator cover or converter case.
- Do NOT touch any open cable connections on the unit while the power is turned ON.
- Do NOT operate generator with converter disconnected from high voltage cable. High voltage is present in the cable and may pose a shock hazard.
- Do NOT attempt to disconnect the converter high voltage cable while the unit is running.
- The generator must be properly grounded with a 3-prong plug. Test electrical outlet for proper grounding before plugging in unit.
- Install the Sonic Dismembrator in an area free from excessive dust, dirt, explosive or corrosive fumes and protected from extremes in temperature and humidity. Do not place the Generator within a Fume Hood.
- Hearing protection is highly recommended. It is recommended that a sound abating enclosure or ear protection be used when operating the Ultrasonic Processor
- NEVER immerse the converter in liquids of any kind, or let condensed moisture or liquid drip into the converter.
- NEVER grasp an activated horn or touch the tip of a vibrating probe. It can cause severe burns and tissue damage.
- NEVER allow a microtip to vibrate in air for more than 10 seconds.
- NEVER hold or clamp the converter by the front driver or by the horn itself. This can cause permanent damage to the system. Support the converter by only clamping around the converter housing (upper portion).
- Do NOT allow the tip of a vibrating horn or probe to touch the counter top or any other hard surface. It could damage the probe, overload the generator, or damage the surface.
- Avoid touching the bottom or sides of a glass or plastic container with an activated probe. It could crack or shatter the glass or melt the plastic.
- Turn OFF the power switch, unplug the generator and disconnect the power cord from the back of the generator before attempting to replace the fuses.
- Inspect high frequency cable for cracks in the protective outer jacket.
- Do not operate unit with a damaged cable. Doing so may cause serious injury.
- In case of AC power loss, wait 3 minutes minimum before reapplying power.
- Do not turn off AC mains power while running a horn. Stop sonication through the touch screen prior to removing AC power.

Symbols



Caution, Risk of electric shock, Hazardous voltage.



Caution, Risk of danger. Refer to User Manual.

3. Specifications

<u>Generator</u>		
Input Voltage	100 VAC – 120 VAC @ 50/60 Hz	220 VAC – 240 VAC @ 50/60 Hz
Rated Current	2.4 Amps max.	1.2 Amps max.
Fuse Rating	3 Amps (slo-blo)*	1.6 Amps (slo-blo)*
Weight	7 lbs. (3.2 Kg)	
Dimensions	8"W x13"L x 6"H 203mm x 330mm x 152mm	
Output Voltage	1000 V rms (max.)	
Output Frequency	20 KHz	

<u>Converter</u>	
Weight	0.75 lbs. (0.34Kg)
Dimensions	6" L x 1.25" Dia. (15cm x 3cm)
Materials	Aluminum Alloy

<u>Standard 1/8" Microtip</u>	
Weight	0.25 lbs. (0.11Kg)
Dimensions	5.4" L x 0.5" Dia. (13.8cm x 1.3cm)
Materials	Titanium Alloy

Environmental	
Pollution Degree	2
Installation Category	II
Operating Limits	Temperature: 41 - 104°F (5 - 40°C) Relative Humidity 10 - 95% (Non Condensing) Altitude: 6,651 ft. (2000 m)
Shipping/Storage	Temperature: 35 -120 °F (2 - 49 °C) Relative Humidity 10 - 95% (Non Condensing) Ambient Pressure Extremes: 40,000 ft. (12,192 m)
Restriction of Hazardous Substances (ROHS)	
Relative humidity	Maximum relative humidity 80% for temperatures up to 31°C decreasing linearly to 50% relative humidity to 40°C
Other	For indoor use only

*Only use IEC approved Slo-blo fuses, Cooper Bussman

The Power Cord supplied with the ultrasonic processor must be used. If the 220V plug is not configured to match the wall receptacle, a properly grounded universal AC socket adapter must be added.

Important: Universal adapters do not convert voltage or frequency. Fisher is not responsible for damage caused by the use of an improper power cord or adapter. Transformers are not recommended.



WEEE Statement

This product contains electrical or electronic materials. The presence of these materials may, if not disposed of properly, have potential adverse effects on the environment and human health. Presence of this label on the product means it should not be disposed of as unsorted waste and must be collected separately. As a consumer, you are responsible for ensuring that this product is disposed of properly. To find out how to properly dispose of this product contact Customer Service.

4. Principles of Operation

The ultrasonic electronic generator transforms AC line power to a 20 KHz signal that drives a piezoelectric converter/transducer. This electrical signal is converted by the transducer to a mechanical vibration due to the characteristics of the internal piezoelectric crystals.

The vibration is amplified and transmitted down the length of the horn/probe where the tip longitudinally expands and contracts. The distance the tip travels is dependent on the amplitude selected by the user through the touch screen pad. As you increase the amplitude setting the sonication intensity will increase within your sample.

In liquid, the rapid vibration of the tip causes cavitation, the formation and violent collapse of microscopic bubbles. The collapse of thousands of cavitation bubbles releases tremendous energy in the cavitation field. The erosion and shock effect of the collapse of the cavitation bubble is the primary mechanism of fluid processing.

The probe tip diameter dictates the amount of sample that can be effectively processed. Smaller tip diameters (microtip probes) deliver high intensity sonication but the energy is focused within a small, concentrated area. Larger tip diameters can process larger volumes, but offer lower intensity.

The choices of a generator and horns/probes are matched to the volume, viscosity and other parameters of the particular application. Horns are available for both direct and indirect sonication. The Accessories section has more information on this subject.

Please consult with a product specialist for assistance with selecting a probe for your application.

Relationship of Amplitude and Wattage

Sonication power is measured in watts. Amplitude is a measurement of the excursion of the tip of the probe (probe is also known as a horn).

Some ultrasonic processors have a wattage display. During operation, the wattage displayed is the energy required to drive the radiating face of a probe, at that specific amplitude setting against a specific load, at that particular moment. For example, the unit experiences a higher load when processing viscous samples then when compared to aqueous samples.

The speed /cruise control on an automobile, can, to a certain extent, be compared to an ultrasonic processor. The speed/cruise control is designed to ensure that the vehicle maintains a constant rate of travel. As the terrain elevations change, so do the power requirements. The cruise control senses these requirements, and automatically adjusts the amount of power delivered by the engine in order to compensate for these ever changing conditions. The greater the terrain rate of incline and greater the resistance to the movement of the vehicle, the greater the amount of power that will be delivered by the engine to overcome that resistance and maintain a constant speed.

The ultrasonic processor was designed to deliver constant amplitude, to your liquid sample, regardless of these changes in load (much like the vehicle's cruise control described above). As a liquid is processed, the load on the probe will vary due to changes in the liquid sample (i.e. viscosity, concentration, temperature, etc.). As the resistance to the movement of the probe

increases (increased load on the probe), additional power will be delivered by the power supply to ensure that the excursion at the probe tip remains constant. The displayed wattage readings will vary as the load changes, however the amplitude will remain the same.

The resistance to the movement of the probe determines how much power will be delivered to maintain amplitude. For example, a ½” probe at 100% amplitude will require approximately 5 watts to operate in air. The amplitude of this probe is approximately 120um. Insert the probe in water and the wattage reading will increase to approximately 90 watts. The wattage required to operate the probe will increase as the load increases but the amplitude remains the same.

The AMPLITUDE control allows the ultrasonic vibrations at the probe tip to be set to any desired level. Although the degree of cavitation/ultrasonic energy required to process the sample can readily be determined by visual observation, the amount of power required cannot be predetermined. A sensing network continuously monitors the output requirements, and automatically adjusts the power to maintain the amplitude at the preselected level. The greater the resistance to the movement of the probe due to higher viscosity, deeper immersion of the probe into the sample, larger probe diameter or higher pressure, the greater the amount of power that will be delivered to the probe. Setting the AMPLITUDE control to its maximum will not cause the maximum power rating of the unit to be delivered to the sample. The maximum power (120 watts) that the Ultrasonic Processor is capable of delivering will only be delivered when the resistance to the movement of the probe is high enough to draw maximum wattage.

It is the intensity of cavitation that measures the effectiveness of the sonication, not the total power applied to the system. Intensity is directly related to the amplitude of the radiating face of the tip or horn. It is amplitude that must be provided, maintained, and monitored. The unit provides controlled amplitude under varying load conditions in order to give reproducible results.

5. Description of Components / Functions of Controls

The Model # FB-120 includes a standard 1/8" diameter microtip (#FB4422).

FB-120 Front Panel



FB-120 Rear Panel

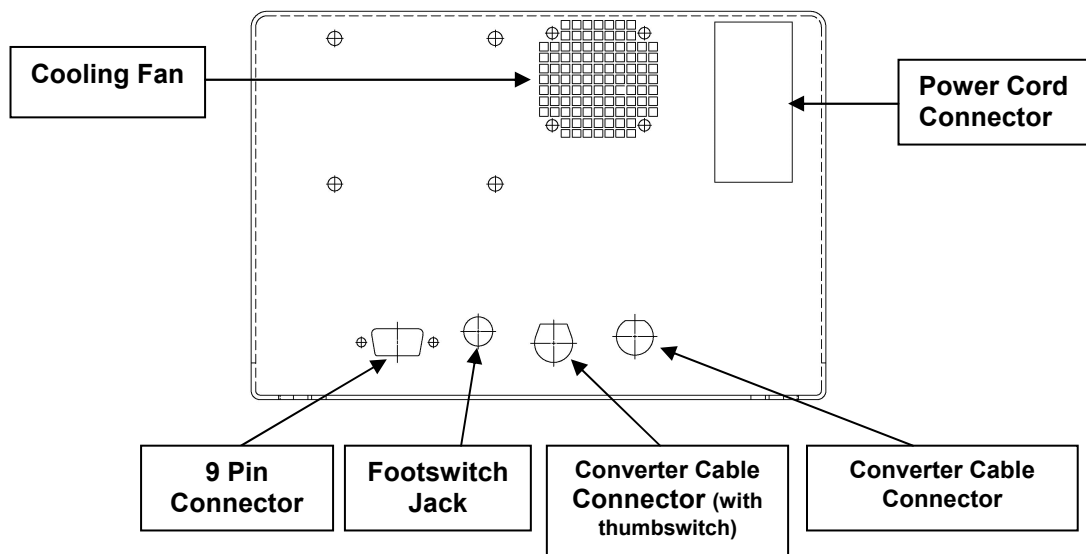

FUNCTIONS OF KEYS, CONTROLS, INDICATORS, AND CONNECTORS

FRONT PANEL	
LCD display	<p>Displays prompts and the following control parameters:</p> <ul style="list-style-type: none"> • Amplitude selected • Amount of output power delivered to the probe in watts, and as a percentage of 120 watts. • Accumulated amount of energy in Joules delivered to the probe.
CLEAR key	Clears the preceding entry.
ENTER REVIEW key	Used to enter the amplitude selected, and view amplitude, power, and energy
START/STOP key	Starts or stops the ultrasonics. In the STOP mode the red indicator goes off.
I ON key	Switches the main power on.
0 OFF key	Switches the main power off.
AMPL	Controls the amplitude of vibration at the probe tip.
▲ ▼ key	Used with the AMPL key when the unit is on stand-by to set the amplitude of vibration at the probe tip. Also used to increase or decrease the amplitude in small increments while the unit is running. To accomplish this task, depress the ENTER/REVIEW key twice to display AMPLITUDE CONTROL, then depress the ▲ or ▼ key as required.
REAR PANEL	
9 pin D-sub connector (IO Port)	Connects to external actuation device, and enable power and frequency monitoring.
Footswitch Connector	Connects to the footswitch cable.
Converter Cable Connector (Output)	Connects to the converter.
Power Supply Connector	Connects to the electrical line cord and encases the fuse(s).

9-PIN D-SUB CONNECTOR	
Pin No.	Description
1	Not connected
2	Not connected
3	Not connected
4	Enables connection to a frequency counter.
5	Enables connection to an external power monitor (5 mv = 1 watt)
6	Ground
7	Energizes the ultrasonics when connected to ground.
8 and 9	Enables the intensity to be remotely adjusted using an external 10k potentiometer.

NOTE: To vary the intensity remotely using a variable DC power supply (0-5V) instead of a 10 K potentiometer, connect positive to pin 8 and negative to pin 6.

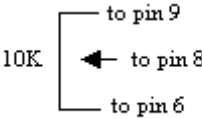

6. Preparation for Use (Getting Started)

INSPECTION

Prior to installing the Ultrasonic Processor, perform a visual inspection to detect any evidence of damage, which might have occurred during shipment. Before disposing of any packaging material, check it carefully for small items.

The Ultrasonic Processor was carefully packed and thoroughly inspected before leaving our factory. The carrier, upon acceptance of the shipment, assumed responsibility for its safe delivery. Claims for loss or damage sustained in transit must be submitted to the carrier.

If damage has occurred, contact your carrier within 48 hours of the delivery date. **DO NOT OPERATE DAMAGED EQUIPMENT.** Retain all packing materials for future shipment.

ELECTRICAL REQUIREMENTS

The Ultrasonic Processor requires a fused, single phase 3-terminal grounding type electrical outlet capable of supplying 50/60 Hz at 100 volts, 115 volts, 220 volts, or 240 volts, depending on the voltage option selected. For power requirements, check the label on the back of the unit. Should it become necessary to convert the unit for different voltage operation, proceed as follows.

1. Ensure that the power cord is not connected to the electrical outlet.
2. Open the fuse holder cover using a small screwdriver.
3. Pull out the red fuse holder from its housing.
4. To convert from 100/115V to 220/240V replace the two 3 Amp slow blow fuses, with 1.6 Amp fuses.
5. To convert from 220/240V to 100/115V reverse the procedure above.
6. Rotate the fuse holder 180° from its original position, and reinsert it into its housing. For 100/115V operation the voltage displayed should be 115. For 220/240V operation the voltage display should be 220.
7. Change the electrical power cord as required.



WARNING

For your personal safety, do not, under any circumstances, defeat the grounding feature of the power cord by removing the grounding prong.

INSTALLING THE ULTRASONIC PROCESSOR

The Ultrasonic Processor should be installed in an area that is free from excessive dust, dirt, explosive and corrosive fumes, and extremes of temperature and humidity. If processing flammable liquids use an approved fume hood and do not place the power supply in the fume hood.

When positioning the unit, be sure to leave adequate space behind the unit so that all connections can be easily disconnected.

7. Operating Instructions

CAUTION

- Do not operate the power supply unless it is connected to the converter.
- Never allow liquid to spill into the converter.
- Do not allow a microtip to vibrate in air for more than 10 seconds.
- Do not allow the vibrating microtip to contact anything but the sample.
- Never place a washer between the probe and the converter.
- Never apply grease to the mating surfaces or threads of the converter, probe or microtip.
- Should it become necessary to remove a probe, use the wrenches supplied. Never attempt to remove the probe by twisting the converter housing, as this may damage the electrical connections within the housing.

Set-up:

1. Plug the electrical line cord into the electrical outlet. If the unit is already on, depress the **OFF** key.
2. If the optional foot switch is used, insert the plug into the jack located on the rear panel.
3. If the converter and probe assembly is not already assembled; screw the probe onto the converter and using the wrenches provided tighten it securely. (See instruction in Maintenance section for attaching and detaching microtips).
4. If using a laboratory stand, mount the converter /probe assembly using a clamp. Be sure to secure the clamp to the upper section of the converter housing only. Do not secure the clamp to any other portion of the converter/probe assembly.
5. Connect the converter cable to the power supply.

Operation:

Press the **ON** key. The screen will display the power rating of the Ultrasonic Processor and the following control parameters.

Time - : --: --	
Pulse -- --	Ampl -- %

AMPLITUDE: Desired amplitude must be set in order for the Ultrasonic Processor to be operational. The other control parameters – Time and Pulse, do not have to be set for continuous operation. **AMPL** displays the amplitude selected e.g. 40%. To set the amplitude at 40% when the ultrasonics is off, press the **AMPL** key and the numeric keys for a 40% reading on the screen, and then press the **ENTER/REVIEW** key.

Note: The minimum amplitude setting is 20%.

The screen will display:

Time - : --: --	
Pulse -- --	Ampl 40 %

NOTE: To clear an incorrect entry press the **CLEAR** key.

1. Immerse the microtip half way into the sample. If the probe is immersed to an insufficient depth, air will be injected into the sample, causing the sample to foam. Also ensure that the probe tip is not touching the wall of the sample vessel as it may be damaged and it will not vibrate properly.
2. The Ultrasonic Processor is now ready for continuous operation. To energize the ultrasonics, press the **START** key or the footswitch. To de-energize the ultrasonics, press the **STOP** key or release the footswitch. If the Time or Pulse functions must be used, refer to the appropriate paragraphs below.
Note: The **START** key and footswitch are mutually exclusive. If the process is initiated by the **START** key, the footswitch becomes inoperative. If the process is initiated by the footswitch, the **STOP** key becomes inoperative.
3. To increase or decrease the amplitude in small increments when the ultrasonics is on, depress the **AMPL** to display Amplitude Setting on the screen, then depress the **▲** or **▼** key, as required. Since the amplitude required is application dependent and subject to the volume and composition of the sample, it is recommended that the amplitude be selected through experimentation, by increasing or decreasing the level of intensity as needed to properly process the sample to achieve desired results.

TIMER: In the pulsed mode the processing time will be different from the elapsed time because the processing time function monitors and controls only the ON portion of the duty cycle. For example, for 1 hour processing time, the elapsed time will be 2 hours if the ON and OFF cycle are set for 1 second.

1. To set the processing time, press the **TIMER** key.

The screen will display:

Time Setting
Hrs: - Min: -- Sec: --

2. Using the numeric keys, set the processing time as required, for example:

Time Setting
Hrs: 0 Min: 30 Sec: 00

3. Press the **ENTER/REVIEW** key. The screen will display:

Time 0:30:00
Pulse -- -- Ampl 40 %

PULSER: Ultrasonics generates heat. Pulsing ultrasonics on and off helps to prevent heat build up in temperature sensitive samples. In addition, pulsing enhances processing by allowing the material to settle back under the probe after each burst. The ON and OFF pulse duration can be set independently from 01 second to 59 seconds. During the OFF portion of the cycle, the red indicator on the **PULSE** key will illuminate. If the OFF portion of the cycle exceeds three seconds, a cautionary message - Sonics in OFF Cycle - will warn the operator against touching the ultrasonic probe.

1. To set the pulser, press **PULSE** key.

The screen will display:

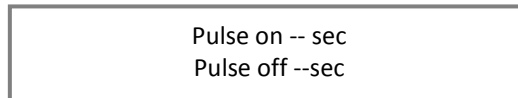

Pulse on -- sec
Pulse off --sec

2. Using the numeric keys, set the ON portion of the cycle, and press the **ENTER/REVIEW** key.

The screen will display:

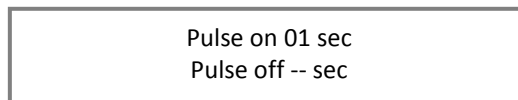

Pulse on 01 sec
Pulse off -- sec

3. Using the numeric keys set the OFF portion of the cycle.

The screen will display:

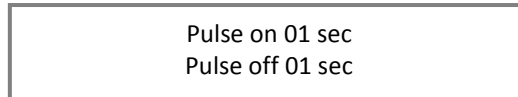

Pulse on 01 sec
Pulse off 01 sec

4. Press the **ENTER/REVIEW** key.

The screen will display:



Time 0:30:00
Pulse 01 01 Ampl 40 %
On Cycle Off Cycle

REVIEW: The REVIEW function provides a “window” on the process by displaying various operating parameters without process interruption. Pressing the **ENTER/REVIEW** key repeatedly during processing will consecutively display the following information.

- a) Selected amplitude:
e.g. Amplitude 40%

- b) Selected processing time and elapsed processing time:
e.g. Set 0:30:00 Time 0:22:10

- c) Selected pulsing cycle and actual pulsing cycle:
e.g. Pulse 01 01 / 01 00

- d) Amount of power in watts, and accumulated amount of energy in JOULES delivered to the probe (Note: ***The amount of energy displayed will be only for one cycle. Initiating a new cycle will reset the display to zero.***):
e.g. 20 watts 0000000 Joules

- e) Elapsed time since processing was initiated:
e.g. Elapsed time 0:44:20

Refer to Section 10 if an overload condition exists.

8. Accessories

A. 5/64" probe (0.2 - 5ml), Catalog #FB4423



B. 1/8" probe (0.5 – 15 ml), Catalog #FB4422



C. 1/4" probe (5 - 50ml), Catalog #FB4435



D. 8 tip horn, Catalog #FB4602



E. 1.5" cup horn, Catalog #FB4447



F. Stand with clamp (20" x 10" x 10"), Catalog # FB460



G. Sound Enclosure with Clamp (20" x 10" x 10"), Catalog #FB432A



H. Footswitch, Catalog #FB4004



9. Maintenance

It is recommended to periodically inspect the unit, both visually and physically, to insure optimum and safe performance. This inspection should be scheduled as a routine maintenance procedure, done with the unit power **OFF** and with the unit unplugged from the AC power source.

Long exposure to acids or caustics results in corrosion of metal parts or components. Check the generator, converter, and cables periodically for any signs of rust or discoloration. If discoloration is found, move the ultrasonic processor away from the source of the contaminant.

Examine the condition of the high voltage cable that attaches the converter to the generator. Inspect the wire insulation for damage, such as wear, burning from hot plate contact or breakage from extended use or rough handling. In general use, the cable assembly should not be used to carry the converter or pull it toward the user. Make certain the cable always has slack and is never tensioned. If necessary, move the generator or converter assembly closer to one another to accomplish this. **WARNING: Do not use a cable with broken end connections, exposed wires or frayed insulation. High voltage is present in the cable and will pose a shock hazard. Do not touch the converter assembly until the power switch is off and the unit is unplugged.**

Microtip/ Probe Maintenance

Ultrasonic processors create high intensity vibration which puts stress on the converter and horn assembly. The sides and end of the probe must **never** be allowed to come in contact with anything but the solution. When using a Microtip, the stress resulting at the point of contact with the vessel could cause the Microtip to fracture.

Proper care of the probe is essential for dependable operation. The intense cavitation will, after usage for period of time, cause the tip to erode, and the power output to decrease. The smoother and shinier the tip, the more power will be transmitted into the sample. The vibrations may also cause the probe tip to loosen over time or the threaded connection to accumulate debris. **Note:** *A loose probe will usually generate a loud piercing or squealing sound.*

For that reason, **it is recommended that a preventative maintenance schedule be adopted to examine the unit at regular intervals.** The schedule should depend on frequency of use. Weekly maintenance schedules are recommended for units used frequently or monthly for those used infrequently. The tip must be examined for excessive wear and to ensure that the threaded connection is clean and attached properly to the converter. Use a cotton swab and alcohol (i.e. ethanol, isopropyl, etc.) to clean the threaded mating surfaces.

When excessive wear (corrosion/pitting of the probe tip) is detected the probe should be replaced with a new one.

WARNING: Never hand tighten probes or horns onto the convertor; properly tighten them with the appropriate Wrench Set.

Follow the steps below for attaching and detaching microtip probes:

1. *Disconnect probe from convertor. Use the wrench set provided with the system.*

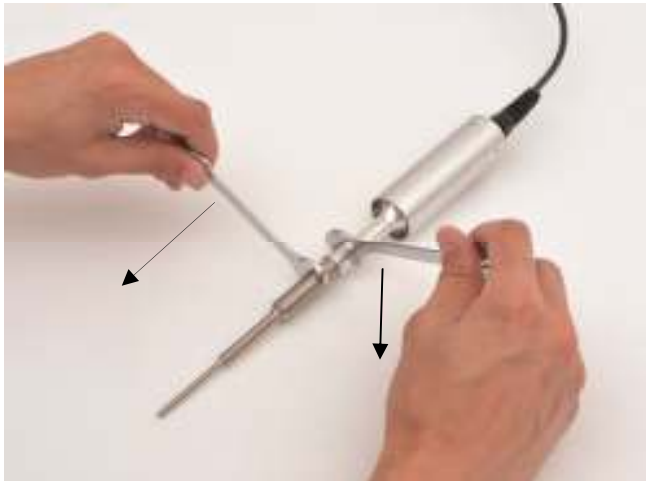

2. *Clean threaded stud. Use alcohol and a cotton swab to remove any debris on the threading of the connecting stud. Allow the alcohol to dry completely.*
3. *Clean threading in convertor. Use alcohol and a cotton swab to remove any debris on the threading. Do not allow liquid to drip into Convertor. Allow the alcohol to dry completely.*
4. *Reattach probe to convertor. Screw the probe back onto the convertor and tighten with the wrench set provided.*

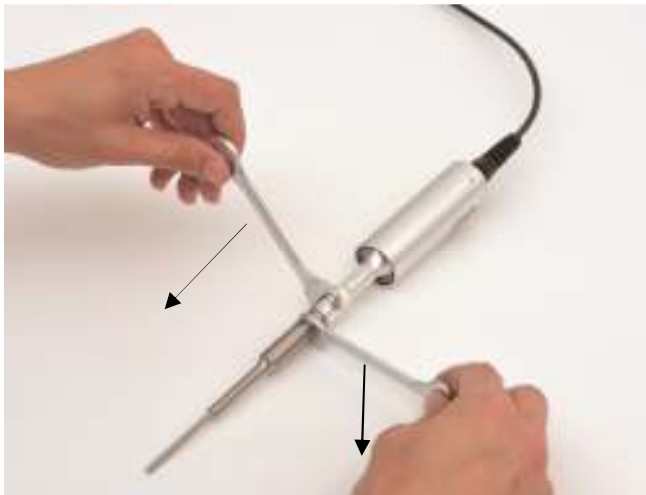

System Cleaning Instructions

The generator and converter may be cleaned using an acid-free cleaning solution (i.e. glass cleaner).

Probes should be cleaned using isopropyl alcohol. Probes are made from titanium and can be autoclaved (the converter is an electrical part and cannot be sterilized in this manner). Before each procedure place the probe tip in water or alcohol and turn the power on for a few seconds to remove residue. The tip also can be sterilized using alcohol with the power on.

10. Troubleshooting

Your Ultrasonic Processor was designed to provide you with years of safe and dependable service. Nevertheless, because of component failure or improper usage, the possibility does exist that it might not perform as it should, shut down or stop working all together. The most probable causes for malfunction are listed below and should be investigated.

- A connector or cable is damaged.
- The unit was plugged into an electrical outlet that provides a different voltage from that required. See *Electrical Requirements*.
- The microtip is not tightened properly with the wrenches provided.
- The convertor and/or microtip has been dropped.
- A microtip being operated is damaged or worn past its useful life.
- A fuse(s) has failed. If a fuse(s) has failed, proceed as follows:
 1. Turn the unit off by depressing the **OFF** key, and disconnect the line cord from the electrical outlet.
 2. Open the fuse holder cover using a small screwdriver, and pull out the red fuse holder from its housing.
 3. Replace the fuse(s).
 4. Reconnect the line cord to the electrical outlet, press the **ON** key and set the amplitude to 100. With the probe in air (out of the sample), the wattmeter should read below 10 watts. If the reading exceeds 10 watts, press the **OFF** key, and disconnect the probe from the converter.
 5. Press the **ON** key. If the wattmeter reads below 10 watts, the probe has failed or is out of tune due to excessive erosion, and should be replaced, if the wattmeter reads above 20 watts, either the converter or power supply has failed and the complete Ultrasonic Processor should be returned for repair.

OVERLOAD CONDITION

If the Ultrasonic Processor stops working, and an OVERLOAD indication is displayed on the screen, check for possible causes as outlined in the above paragraph, then press the **OFF** key to switch the unit off, and the **ON** key to switch the unit back on.

If the problem persists after inspecting all of these, please contact Customer Service for additional assistance or to replace a worn microtip or damaged part.

11. Return of Equipment

It is suggested that an Ultrasonic Processor in need of repair be sent back to the factory.

In order to receive prompt service; always contact your Customer Service Representative before returning any instrument. Include date of purchase, model number and serial number.

Please obtain a *Return Authorization Number* prior to returning the instrument.

Care should be exercised to provide adequate packing to insure against possible damage in shipment. The Ultrasonic Processor should be sent to the "Service Department" with all transportation charges prepaid and return of shipment indicated.

Important

The user must certify that the ultrasonic processor and/or the accessories returned for repair are free of any biohazardous or radioactive material and are safe for handling.

Do not return any equipment unless such a certification can be made.

SAFETY CERTIFICATION FORM

Items being returned:

Please check only one item below:

The equipment was never used or exposed to any radiological, biological or chemical agents and is safe to handle, use or dispose of.

The equipment was used but not in conjunction with or exposed to any radiological, geological or chemical agents and is safe to handle, use, or dispose of.

The equipment was used in conjunction with or exposed to radiological, biological, or chemical agents and has been decontaminated, rendering it safer for handling, use, or disposal.

Authorization

By accepting authorization to return the equipment listed above, the undersigned assumes all responsibility and liability for radiological, biological and chemical decontamination. Delivery of the equipment can be refused if necessary documentation is not provided or where it is determined that the equipment has not been properly decontaminated. If it is determined that the equipment was not properly decontaminated, the Authorized Repair Facility reserves the right to bill the customer for any and all costs associated with the decontamination and/or appropriate disposal of the equipment. In the event the equipment has been exposed to radiological contamination, the signature of the Radioactive Safety Officer is required.

Print name: _____ RA # _____

Signature: _____ **Date:** _____