



accumet®

AP 110

AP 115

AP 125



INSTRUCTION MANUAL



DRAFT 68X452201 Rev. 1 06/08

Thank you for selecting an accumet portable (AP) meter. This portable meter is a microprocessor-based instrument with many user-friendly features, all of which are accessible through the keypad. Please read this manual thoroughly as well as your separate electrode manual before operating your instrument.

TABLE OF CONTENTS

1. THE INSTRUMENT	1
1.1. DISPLAY	2
1.2. KEYPAD	3
1.3. CONNECTORS	4
2. BATTERY INSTALLATION	5
3. FEATURES	5
4. ELECTRODE USE	5
5. pH OPERATION	6
5.1 Using Setup in pH mode	6
5.2 pH Standardization	7
5.3 pH Measurement	8
6. mV OPERATION	9
6.1 Using Setup in mV mode	9
6.2 mV Measurement	10
7. R.mV OPERATION	10
7.1 Using Setup in R.mV mode	10
7.2 R.mV Standardization	11
7.3 R.mV Measurement	11
8. ION OPERATION (AP125 only)	11
8.1 Using Setup in the Ion mode	12
8.2 Ion Standardization	13
8.3 Ion Measurement	14
9 MEASURING TEMPERATURE	15
9.1 Temperature Standardization (ATC)	15
9.2 Temperature Standardization (MTC)	15
10 DATA STORAGE	16
10.1 Storing Value into Memory	16
10.2 Recalling Value from Memory	16
11. SPECIFICATIONS	17-18
11. ERROR MESSAGES	179
13. REPLACEMENT PARTS & ACCESSORIES ...	179

1. THE INSTRUMENT

Before operating the meter, please familiarize yourself with the location and function of its various display elements, keypad and connectors.

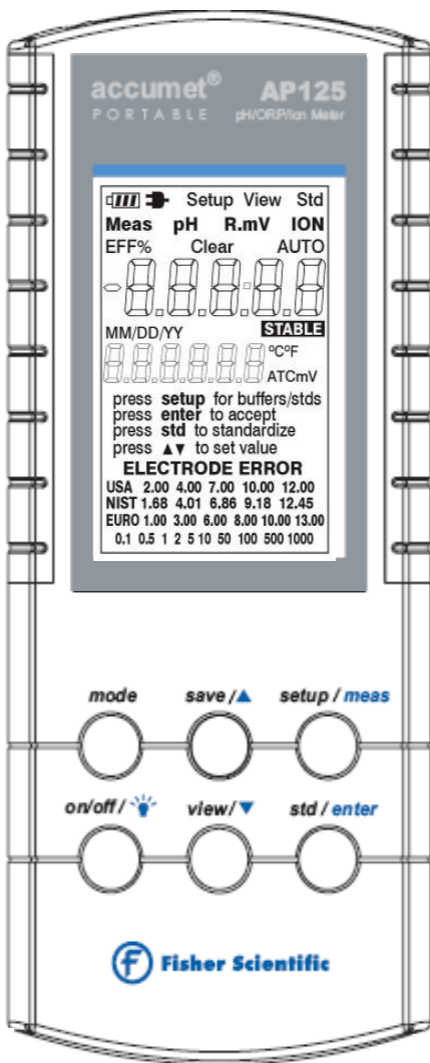

Figure 1 Front view of meter

1.1 DISPLAY

Figure 2 illustrates the liquid crystal display area. Each of the display elements is referenced in the figure and described below.

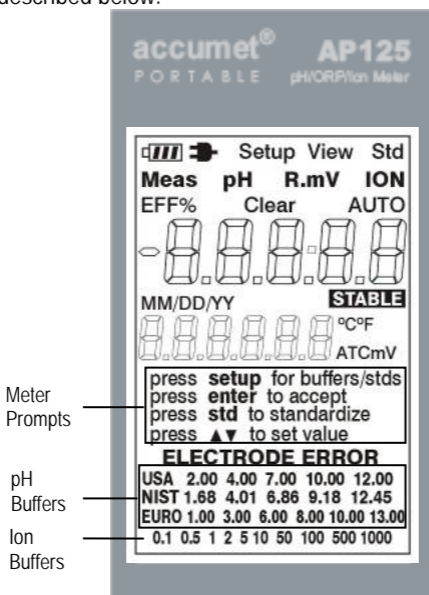

Figure 2 Display annunciators

SYMBOL	DESCRIPTION
	Battery indicator with scale
	Meter operating with optional AC power supply
Setup	Set Up mode
View	View data stored in memory
Std	In Standardization mode
Meas	In Measurement mode
pH	pH Measurement mode
R.	Relative millivolt Measurement mode
mV	Absolute millivolt Measurement mode
ION	Ion Measurement mode
STABLE	Reading stability indicator
EFF%	Slope efficiency in percentage
Clear	Clear (erase) data
AUTO	Auto-read function ON
MM/DD/YY	Month/Date/Year
°C	Temperature in Degrees Celsius
ATC	Automatic Temperature Compensation
mV	Offset in millivolts

1.2. KEYPAD

Figure 3 illustrates the keypad area. The function of each key is described below.

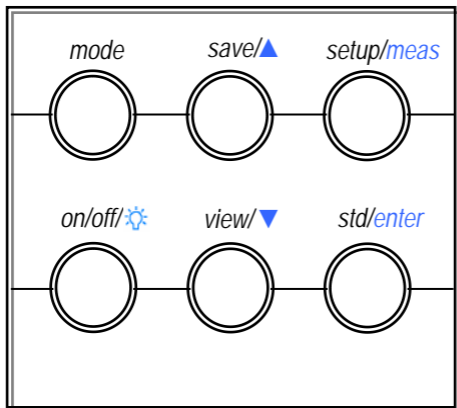

Figure 3 Meter Keypad

on/off	<p>Press to turn the meter ON. The meter will default to the last measurement mode used.</p> <p>When ON, press this key to turn the backlight ON or OFF (to conserve batteries, the backlight is automatically turned off after 30 seconds).</p> <p>When ON, press and hold this key for 3 seconds to turn the meter OFF.</p>
mode	Press this key to toggle between pH, mV, Relative mV (R.mV) and Ion (AP125 only) measurement modes
setup/meas	Press this key to enter Setup menu. Press again to scroll through the Setup options
std/enter	Press this key to activate and confirm the standardization. Also to confirm selection or change being made in Setup mode.
save/▲	Press this key to store measured data into memory (up to 200 data sets). Also to increase value e.g. for date and time setting scroll up selection.
view/▼	Press this key to recall and select memory location of stored data. Also to decrease value e.g. for date and time setting scroll down selection.

1.3 CONNECTORS

Figure 4 illustrates the Top View showing connectors of the AP meter.

Note that the meter is waterproof only when the blue rubber plugs and/or the appropriate ATC probe are used. If the meter is totally submersed, water may enter the BNC connector. If necessary, dry the connector to avoid corrosion. Also, If an AC adapter is connected, the meter is not waterproof.

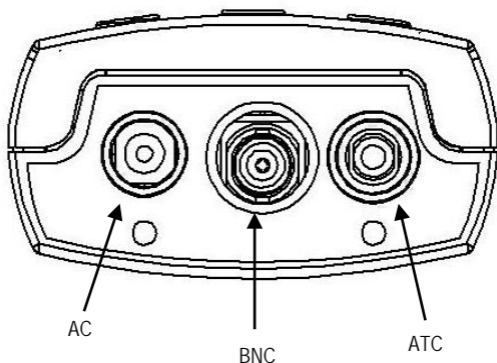

Figure 4 View of Connectors

The **AC jack** is used to connect an optional power adapter. If an AC adapter is not used, Seal the jack with the blue rubber plug to maintain a waterproof state. An AC adapter prevents battery drain by removing the battery from the circuit.

For pH, mV, R.mV, and Ion measurement, attach combination electrodes with BNC connectors directly to the middle **BNC jack** on the meter. Non-combination (half cell) electrodes can be used with appropriate adapters sold separately.

For best results, automatic temperature compensation (ATC) is recommended. Insert the accumet waterproof ATC connector into the **ATC jack**. Insert the attached blue rubber plug if an ATC probe is not used to maintain a waterproof state.

3. FEATURES

FEATURE	DESCRIPTION
Display Resolution	Operator-selectable using setup/meas key, choose 88.88 for 0.01, 88.888 for 0.001
Auto Read	When enabled, display locks on current value when stable indicator appears. Press meas key to unlock and resume reading
Battery Saver	When enabled, meter automatically turns off after 23 minutes of inactivity
Backlight	To conserve battery life, the backlight automatically turns OFF after 30 seconds
Slope Display	View electrode slope and mV offset for current reading with setup/meas key
Auto-buffer Recognition	Meter selects from 5 (USA or NIST) or 6 (EURO) pre-programmed standards with temperature correction of buffer value
Standardization	User selectable 1-5 cal points for USA/NIST or 1-6 cal points for EURO standardization.

4. BATTERY INSTALLATION

To install the battery, perform the following steps:

1. Loosen the 3 screws that hold the battery cover at the back of the meter using a Phillips screwdriver.
2. Disconnect the old 9V battery and install new one into meter battery compartment.
3. Make certain the battery wires are positioned so that they do not interfere with the closing of the battery cover. Battery cover edges may damage the wires.
4. Replace the battery cover and tighten the 3 screws to secure the cover in place.

5. ELECTRODE USE

This meter can be directly fitted with combination electrodes, with or without built-in ATC. See **Accessories** section for pH/ATC electrodes as well as adapters for use with half cells.

1. Condition your electrode by soaking as needed in electrode storage solution, pH 4 or 7 buffer, or KCl solution. Complete hydration can take anywhere from minutes to overnight for very dry electrodes.

2. Twist the black shorting cap to remove it from the BNC jack of the meter. Install your electrode by twisting it to lock it in place. The shorting cap is designed to hang freely when the BNC jack is occupied.
3. Rinse the electrode using clean water and gently shake dry between measurements. Store in electrode storage solution, pH 4, pH 7, or KCl solution. If refillable, keep the fill hole open during measurement but close for longer periods of non-use and storage. Refill when the level of fill solution recedes below the manufacturer's recommended level.

Refer to the manufacturer's electrode instruction manual for specific details on electrode use.

6. pH OPERATION

10.1 Using **setup** in pH mode to select options

From the pH **Measure** screen:

The **setup** button is a scroll button which allows you to view and change several operating parameters. While in **setup** you may:

- Press **mode** to return to the Measure screen without making a change or selection
 - Press **setup** and scroll through the operating parameters in the meter
 - Press **enter** to accept the parameter as displayed or to accept a change made to that parameter
1. To activate or de-activate the AUTO hold read function press **setup/meas** once. Select AUTO HOLD 'Yes' or 'No' by using the **save/▲** or **view/▼** keys. Press **std/enter** to accept.
 2. To display the % slope efficiency 'EFF%' and mV offset 'mV' press **setup/meas** twice.
 3. To erase an existing pH standardization/calibration press **setup/meas** until 'Clear buf std'

(Clear buffer standard) appears on the screen. Press **std/enter** to accept or **mode** to cancel.

4. To change the buffer standard group, press **setup/meas** until 'bUF USA' appears. Press **std/enter** accept the desired group (USA, NIST, or EURO) when it is displayed.
5. To change the pH resolution press **setup/meas** until '88888' appears. Press **std/enter** when the desired resolution is displayed below;
88.888 to select 0.001 (AP115 & AP125 only)
888.88 to select 0.01
8888.8 to select 0.1
6. To activate or deactivate the Automatic Shut off function press **setup/meas** until 'A.Off' appears. Select 'Yes' or 'No' by using the **save/▲** or **view/▼** keys and press **std/enter** to confirm your selection. If 'Yes' is selected, the meter automatically turns off after 23 minutes of inactivity. **Note: Selecting 'No' can result in total battery exhaustion—once on, the meter remains on until the meter is manually turned off.**
7. To set meter time and date press **setup/meas** until 'MM/DD/YY' appears. Use the **save/▲** or **view/▼** keys to select the appropriate digits. Press **std/enter** to confirm selection and to move from minutes to hours; or from month to day to year.
8. To clear data memory press **setup/meas** until 'Clear dAtA' appears. Select 'Yes' or 'No' by using the **save/▲** or **view/▼** keys. Press **std/enter** to confirm selection.

10.2 pH Standardization

For best results, standardizing (calibrating) your meter/ electrode system against certified accurate solutions is strongly recommended due to electrode variations and changes in electrode response over time. Daily standardization with fresh buffers is common.

1. Press **mode** until the display indicates the pH mode.
2. Immerse the rinsed electrode(s) into a buffer from the chosen group (USA, NIST or EURO). Stir moderately if possible. Buffers can be used in any order, however neutral (pH 7) is ideally first.
3. Press **std/enter** to access the Standardize screen. 'Std' is now displayed indicating this mode.
4. Allow the pH value to reach a constant reading (little variation over 30 seconds as well as the appearance of the **STABLE** annunciator). Press **std/enter** again to complete standardization of the value. The meter automatically recognizes the buffer and returns to the Measure mode. Successfully standardized buffer values remain on the display until cleared—even after power off.
5. Repeat steps (2) to (4) with subsequent buffers. The meter will briefly display 'EFF%' (efficiency as % slope) before returning to the Measure mode.

If this value is not between 70-120%, '**SLOPE Error**' (Electrode error) is displayed. The standardization value is not accepted and the instrument returns to the Measure mode.

10.3 pH Measurement

1. Press **mode** until the display indicates the pH mode. Immerse the electrode(s) into the sample solution. Stir moderately if possible.
2. Allow the pH value to reach a constant reading (little variation over 30 seconds as well as the appearance of the **STABLE** annunciator). The pH reading may be recorded at this time.
 - a. If **AUTO** is not displayed, the auto read hold function is not active, and the meter will continuously monitor the live pH value.
 - b. If **AUTO** is displayed, the meter will lock the measured value on the screen when the

STABLE annunciator appears. To release the locked value and obtain a new reading, press **setup/meas**. **AUTO** will flash until a stable reading is obtained and the new value is locked. **Note: enabling the AUTO read hold function can lead to erroneous values if the electrode is slow to respond such as testing of viscous or dirty samples, changing temperatures, etc.**

11. mV OPERATION

AP meters display absolute mV values—referenced to zero mV. Although, calibration doesn't apply to absolute measurement, a check of the zero value can be performed by connecting the BNC shorting cap and observing the mV reading. See **Relative R.mV** section for offset standardization.

11.1 Using **setup** in mV mode to select options

1. Press **mode** to select mV measurement mode.
2. To change the mV resolution press **setup/meas** until '88888' appears. Press **std/enter** when the desired resolution is displayed below:
8888.8 to select 0.1
8888 to select 1
3. To activate or deactivate the Automatic Shut off function press **setup/meas** until 'A.Off' appears. Select 'Yes' or 'No' by using the **save/▲** or **view/▼** keys and press **std/enter** to confirm your selection. If 'Yes' is selected, the meter automatically turns off after 23 minutes of inactivity. **Note: Selecting 'No' can result in total battery exhaustion—once on, the meter remains on until the meter is manually turned off.**
4. To set meter time and date press **setup/meas** until 'MM/DD/YY' appears. Use the **save/▲** or **view/▼** keys to select the appropriate digits. Press **std/enter** to confirm selection and to move from minutes to hours; or from month to day to year.

5. To clear data memory press **setup/meas** until 'Clear dAtA' appears. Select 'Yes' or 'No' by using the **save/▲** or **view/▼** keys. Press **std/enter** to confirm selection.

11.3 mV Measurement

1. Press **mode** until the meter displays the mV mode.
2. Immerse the electrode in sample solution.
3. When the meter senses that the displayed value is stable, **STABLE** will appear under the displayed value. Record the reading at this time.

Note: The **AUTO** read function is not applicable in the mV and R.mV measurement modes.

12. R.mV OPERATION

AP meters can display relative mV (R.mV) values i.e. all values are referenced to a specified offset mV.

12.1 Using **setup** in R.mV mode to select options

1. Press **mode** to select R.mV measurement mode.
2. To view saved offset mV value, press **setup/meas** once. If no offset exists, '----' will be displayed. Press **std/enter** to accept the offset value.
3. To erase an existing Relative mV standard press **setup/meas** until '**Clear rEL Std**' (Clear relative mV standard) appears. Press **std/enter** to accept or **mode** to cancel.
4. To change the R.mV resolution press **setup/meas** until '88888' appears. Press **std/enter** when the desired resolution is displayed below;
8888.8 to select 0.1
8888 to select 1
5. To activate or deactivate the Automatic Shut off function press **setup/meas** until 'A.Off' appears. Select 'Yes' or 'No' by using the **save/▲** or

view/▼ keys and press **std/enter** to confirm your selection. If 'Yes' is selected, the meter automatically turns off after 23 minutes of inactivity. **Note: Selecting 'No' can result in total battery exhaustion—once on, the meter remains on until the meter is manually turned off.**

6. To set meter time and date press **setup/meas** until 'MM/DD/YY' appears. Use the **save/▲** or **view/▼** keys to select the appropriate digits. Press **std/enter** to confirm selection and to move from minutes to hours; or from month to day to year.
5. To clear data memory press **setup/meas** until 'Clear dAtA' appears. Select 'Yes' or 'No' by using the **save/▲** or **view/▼** keys. Press **std/enter** to confirm selection.

12.2 R.mV Standardization

1. Press **mode** until the display indicates the R.mV mode.
2. Press **std/enter** to access the Standardize screen. Press **std/enter** again to confirm the displayed offset R.mV value to zero.

12.3 R.mV Measurement

1. Press **mode** until the meter displays the mV mode.
2. Immerse the electrode in sample solution.
3. When the meter senses that the displayed value is stable, **STABLE** will appear under the displayed value. Record the reading at this time. This value is the millivolt reading relative to the applied offset.

Note: The AUTO read function is not applicable in the mV and R.mV measurement modes.

13. ION OPERATION (AP125 only)

13.1 Using **setup** in the Ion mode

From the **Measure** screen:

The **setup** button is a scroll button which allows you to view and change several operating parameters. While in **setup** you may:

- Press **mode** to return to the Measure screen without making a change or selection.
 - Press **setup** and scroll through the operating parameters in the meter.
 - Press **enter** to accept the parameter as displayed or to accept a change made to that parameter.
1. To activate or de-activate the AUTO hold read function press **setup/meas** once. Select AUTO HOLD 'Yes' or 'No' by using the **save/▲** or **view/▼** keys. Press **std/enter** to accept.
 2. To display the % slope efficiency 'EFF%' and mV offset 'mV' press **setup/meas** twice.
 3. To erase an existing Ion standardization/calibration press **setup/meas** until 'Clear ION Std' (Clear ion standard) appears on the screen. Press **std/enter** to accept or **mode** to cancel.
 4. To change the Ion resolution press **setup/meas** until '888' appears. Press **std/enter** when the desired resolution is displayed below;
888 to select 123
88 to select 120
8 to select 100
 5. To activate or deactivate the Automatic Shut off function press **setup/meas** until 'A.Off' appears. Select 'Yes' or 'No' by using the **save/▲** or **view/▼** keys and press **std/enter** to confirm your selection. If 'Yes' is selected, the meter automatically turns off after 23 minutes of inactivity. **Note: Selecting 'No' can result in total battery exhaustion—once on, the meter remains on**

until the meter is manually turned off.

6. To set meter time and date press **setup/meas** until 'MM/DD/YY' appears. Use the **save/▲** or **view/▼** keys to select the appropriate digits. Press **std/enter** to confirm selection and to move from minutes to hours; or from month to day to year.
7. To clear data memory press **setup/meas** until 'Clear dAtA' appears. Select 'Yes' or 'No' by using the **save/▲** or **view/▼** keys. Press **std/enter** to confirm selection.

13.2 Ion Standardization

For best results, standardizing (calibrating) your meter/electrode system against certified accurate solutions is strongly recommended due to electrode variations and changes in electrode response over time. Daily standardization with fresh buffers is common.

Please refer to your ion selective electrode manual for calibration standard preparation, maintenance, Ionic Strength Adjuster (ISA), storage and other details not provided here.

1. Press **mode** until the display indicates the Ion mode.
2. Press **std/enter** to access the Standardize screen.
3. Press **setup/meas** to select the desired standard: 0.1, 0.5, 1, 2, 5, 10, 50, 100, 500, 1000
4. Immerse the ion selective electrode(s) into the standard solution selected in Step (3) adding ISA as needed. Provide moderate stirring if possible.
5. Allow the mV value to reach a constant reading (little variation over 30 seconds as well as the appearance of the **STABLE** annunciator). Press **std/enter** again to complete standardization of the value. The meter automatically recognizes the buffer and returns to the Measure mode.

Successfully standardized buffer values remain on the display until cleared—even after power off.

6. Repeat steps (2) to (5) with subsequent standards. The meter will briefly display 'EFF%' (efficiency as % slope) before returning to the Measure mode. If this value is not between 70-120%, '**SLOPE Error**' (Electrode error) is displayed. The standardization value is not accepted and the instrument returns to the Measure mode.

13.3 Measurement in Ion mode

1. Press **mode** until the display indicates the **Ion** mode. Immerse the electrode(s) into the sample solution. Stir moderately if possible.
2. Allow the Ion value to reach a constant reading (little variation over 30 seconds as well as the appearance of the **STABLE** annunciator). The Ion reading may be recorded at this time. **Note: '----' indicates a two point standardization has not been completed and the Ion reading can not be determined. See Ion Standardization.**

If **AUTO** is not displayed, the auto read hold function is not active, and the meter will continuously monitor the live pH value.

If **AUTO** is displayed, the meter will lock the measured value on the screen when the **STABLE** annunciator appears. To release the locked value and obtain a new reading, press **setup/meas**. **AUTO** will flash until a stable reading is obtained and the new value is locked. **Note: enabling the AUTO read hold function can lead to erroneous values if the electrode is slow to respond such as testing of viscous or dirty samples, changing temperatures, etc.**

14 MEASURING TEMPERATURE

AP meters can utilize automatic temperature compensation (ATC) or manual temperature compensation (MTC). The ATC may be separate or integrated into a pH electrode. When ATC is used, temperature is continuously updated and visible on the display. When ATC is not used the meter will display 25°C as the default temperature. AP meters can retain simultaneous temperature adjustments for both ATC (with probe) and MTC (default temp when probe is not used). Temperature is displayed in each Measurement mode—pH, mV, R.mV, and Ion.

14.1 Temperature Standardization (ATC)

The temperature reading of your ATC probe can be adjusted at a single temperature value to ensure optimal accuracy. Standardization of ATC is only recommended when temperature errors are suspected and/or when a replacement temperature probe is used.

1. Press **mode** to select mV measurement mode.
2. Press **std/enter** to access the Standardize screen. 'Std' is now displayed indicating this mode.
3. Dip the ATC probe (or pH/ATC electrode) into a solution of known temperature (i.e. a certified temperature bath). Allow adequate time for the temperature probe reading to stabilize.
4. Set the temperature by using the **save/▲** or **view/▼** keys. The meter allows adjustment up to ± 5.0 degrees compared to the factory default.

14.2 Temperature Standardization (MTC)

When not utilizing an ATC probe for best results, the default temperature reading can be adjusted from the factory default value of 25 °C to ensure optimal accuracy. For example, if your pH buffers and samples are at 20 °C and you do not have an ATC probe, it

would be desirable to change the MTC from 25 °C to 20 °C. If 'ATC' is not displayed, MTC is active.

1. Press **mode** to select mV measurement mode.
2. Press **std/enter** to access the Standardize screen. 'Std' is now displayed indicating this mode.
3. Set the temperature by using the **save/▲** or **view/▼** keys. The meter allows adjustment to any value between 0.0 to 100.0 degrees.

15 DATA STORAGE

15.1 Storing Value into Memory

The AP 110/115/125 meter can store up to 200 data sets in its non-volatile memory.

In any Measurement mode, press **save/▲** to store the measured value. "Lo XX Stored (Location number stored) appears on the screen. The value is now stored in the meter's non-volatile memory and the meter returns to Measurement mode.

If memory is full, the meter will prompt whether to overwrite the data (from the first memory location) or not.

To overwrite the data, select 'Yes', then press **std/enter**. The value is now stored in the meter's non-volatile memory and the meter returns to Measurement mode.

If you do not wish to overwrite the data and wish to escape from this menu, select 'No', then press **std/enter**. The meter will return to Measurement mode without storing the data.

15.2 Recalling Value from Memory

In any Measurement mode, press **view/▼**. The screen will display the latest stored data.

Data retrieval is based on a 'last-in-first-out' basis. To view the specific data; press either **save/▲** or **view/▼** keys to select the appropriate data location number. Press **std/enter** to toggle between data and date & time. Press **mode** to return to the Measurement mode.

SPECIFICATIONS

pH	AP 110	AP 115	AP 125
Range	-2.00 to 20.00	-2.00 to 20.000	
Resolution	0.1 / 0.01	0.1 / 0.01 / 0.001	
Relative accuracy	± 0.01	± 0.002	
Input	BNC		
Input Impedance	10 ¹² ohms		
No. of calibration points	1 to 6 points (depending on Buffer selection)		
Buffer values	USA: 2.00, 4.00, 7.00, 10.00, 12.00 NIST: 1.68, 4.01, 6.86, 9.18, 12.45 EURO: 1.00, 3.00, 6.00, 8.00, 10.00, 13.00		
Min. & max. slope efficiency during calibration	70 to 120 %		
mV	AP 110	AP 115	AP 125
mV Range	± 2000		
Resolution	0.1 / 1		
Relative accuracy	±0.2 / 2		
Relative mV	AP 110	AP 115	AP 125
Absolute mV Range	± 2000		
Resolution	0.1 / 1		
Relative accuracy	±0.2 / 2		
Ion	AP 110	AP 115	AP 125
Range in ppm	NO		1x10 ⁻³ to 9.99x10 ⁴
Resolution	NO		1 or 3 digit
Relative Accuracy	NO		0.5% FS (monovalent) 1% FS (divalent)
Input connector	NO		BNC socket
Input Impedance	NO		1 Gohm
No of calibration points	NO		2- 5 points (min. 2 pts)

Ion	AP 110	AP 115	AP 125
Buffer values	NO		0.1, 0.5, 1, 2, 5, 10, 50, 100, 500, 1000
Min. & max. slope efficiency during calibration	NO		70 to 120 %

Temperature	AP 110	AP 115	AP 125
Temp. Range °C	-5 to 100		
Temp. Resolution	0.1		
Temp. Accuracy	± 0.3		
Features	AP 110	AP 115	AP 125
Date & Time	NO	YES	
Auto-Buffer Recognition	YES		
Auto Hold Mode	YES		
Auto Shut Off	Selectable after 23 minutes, Default (on)		
Memory	200 data sets		
Slope/Offset Display	YES		
Backlight	YES		
Ingress Protection	IP 67		
Operating Temperature	0 to 50 °C		
Battery level indicator	YES		
Battery	9 VDC, PP3		
Battery Life	>200 hours without backlight >20 hours with backlight		
Power Adapter	12 VDC		
Dimensions	1.2" x 2.9" x 6.8"		
Weight	10 ounces		

12. ERROR MESSAGES

ERROR	DESCRIPTION
	Low battery indicator "LobAt" will show on the LCD before the meter goes off. This indicates that battery power is low and that the batteries need to be replaced.
Or	"Over-range" when reading >20 pH, >2000 mV, or >99900 Ion
Ur	"Under-range" when reading <-2 pH or <-2000 mV
CAL Error	Calibration error appears if reading is not within the allowable pH buffer calibration range.
SLOPE Error	Appears if the electrode slope is not within the acceptable 70% to 120% range.

13. REPLACEMENT PARTS & ACCESSORIES

Item Description	Catalog No.
AP110 Meter Only	13-636-AP110A
AP110 Meter Kit	13-636-AP110
AP115 Meter Only	13-636-AP115A
AP115 Meter Kit	13-636-AP115
AP125 Meter Only	13-636-AP125A
AP125 Meter Kit	13-636-AP125
Refillable, pH/ATC electrode, Single Junction	13-620-AP50A
Refillable, pH/ATC electrode, Double Junction	13-620-AP61
Gel-filled, pH/ATC electrode, Double Junction	13-620-AP52
Refillable, ORP/Redox electrode	13-620-81
Ammonia Ion Selective electrode	13-620-509
Chloride Ion Selective electrode	13-620-627
Fluoride Ion Selective electrode	13-620-629
Sodium Ion Selective electrode	13-620-503A
Stainless Steel ATC probe	13-636-AP53
Hard Portable Meter Carrying Case Kit	13-636-AP69
110/220 VAC Power Adapter	13-636-100
pH 4,7,10 Buffer pack, 500 mL bottles	SB105
pH 4,7,10 & Rinse, 20 mL pouches x 5 each	13-300-147

For a complete selection of electrodes and accessories, please refer to the Fisher Scientific Catalog, website, or contact your Fisher Scientific Sales Representative.

To place an order, call 1-800/766-7000, fax 1-800/926-1166, or online www.fishersci.com

For technical support, call 1-888-358-4706 or email accumet@thermofisher.com